

DIGI-VGASD-8X8E



8 INPUT BY 8 OUTPUT MATRIX SWITCHER



Table of Contents

Overview.....	4
Installation	5
Controlling the Matrix.....	8
Transmitting Control Signals.....	17
Using the Matrix with Video Signals other than VGA.....	22
Technical Specifications	23
Warranty	24
Contact Information.....	26

Important Safety Instructions

- **Please completely read and verify you understand all instructions in this manual before operating this equipment.**
- Keep these instructions in a safe, accessible place for future reference.
- Heed all warnings.
- Follow all instructions.
- Do not use this apparatus near water.
- Clean only with a dry cloth.
- Do not install near any heat sources such as radiators, heat registers, stoves, or other apparatus (including amplifiers) that produce heat.
- Use only accessories specified or recommended by Intelix.
- Explanation of graphical symbols:
 - Lightning bolt/flash symbol: the lightning bolt/flash and arrowhead within an equilateral triangle symbol is intended to alert the user to the presence of uninsulated “dangerous voltage” within the product enclosure which may be of sufficient magnitude to constitute a risk of shock to a person or persons. 
 - Exclamation point symbol: the exclamation point within an equilateral triangle symbol is intended to alert the user to the presence of important operating and maintenance (servicing) instructions in the literature accompanying the product. 
- **WARNING: TO REDUCE THE RISK OF FIRE OR ELECTRIC SHOCK, DO NOT EXPOSE THIS APPARATUS TO RAIN OR MOISTURE AND OBJECTS FILLED WITH LIQUIDS, SUCH AS VASES, SHOULD NOT BE PLACED ON THIS APPARATUS.**
- Use the mains plug to disconnect the apparatus from the mains.
- **THE MAINS PLUG OF THE POWER SUPPLY CORD MUST REMAIN READILY ACCESSIBLE.**
- Do not defeat the safety purpose polarized or grounding-type plug. A polarized plug has two blades with one wider than the other. A grounding-type plug has two blades and a third grounding prong. The wide blade or the third prong is provided for your safety. If the provided plug does not fit into your outlet, consult an electrician for replacement of your obsolete outlet. **Caution! To reduce the risk of electrical shock, grounding of the center pin of this plug must be maintained.**
- Protect the power cord from being walked on or pinched particularly at the plugs, convenience receptacles, and the point where they exit from the apparatus.
- Do not block the air ventilation openings. Only mount the equipment per Intelix’s instructions.
- Use only with the cart, stand, tripod, bracket, table, or rack specified by Intelix or sold with the equipment. When/if a cart is used, use caution when moving the cart/equipment combination to avoid injury from tip-over. 
- Unplug this apparatus during lightning storms or when unused for long periods of time.
- **Caution! Shock Hazard.** Do not open the unit. Refer to qualified service personnel. Servicing is required when the apparatus has been damaged in any way, such as power-supply cord or plug is damaged, liquid has been spilled or objects have fallen into the apparatus, the apparatus has been exposed to rain or moisture, does not operate normally, or has been dropped.
- Refer all servicing to qualified service personnel. Servicing is required when the apparatus has been damaged in any way, such as the power-supply cord or plug is damaged, liquid has been spilled or objects have fallen into the apparatus, the apparatus has been exposed to rain or moisture, does not operate normally, or has been dropped.

Overview

Tired of sifting through spec sheets and wiring multiple components from numerous manufacturers? Fed up with long, bulky cable runs? **Simplify with Intelix DIGI-VGASD twisted pair matrices.**

The DIGI-VGASD-8X8e provides eight analog VGA video and stereo audio inputs which may be distributed to eight twisted pair outputs in any combination. In addition, a separate internal control matrix provides bi-directional RS232 and IR switching and distributes the control signals through the twisted pair ports, allowing the remote control of the sources and destinations connected to the matrix. All of the video, audio and control signals are transmitted up to 350 feet on a single twisted pair cable. **In essence, the DIGI-VGASD-8X8e allows you to switch audio, video, and control and transmit it all over a single twisted pair cable to a remote Intelix DIGI-VGASD Series receiver.**

The matrix supports resolutions up to 1920 x 1080, features true hi-fidelity audio, and is compatible with third-party control systems.

Design with Intelix and Design with Intelligence.

DIGI-VGASD-8X8e Package Contents

- DIGI-VGASD-8X8e matrix switcher
- 5VDC power supply
- Manual
- Software CD-ROM

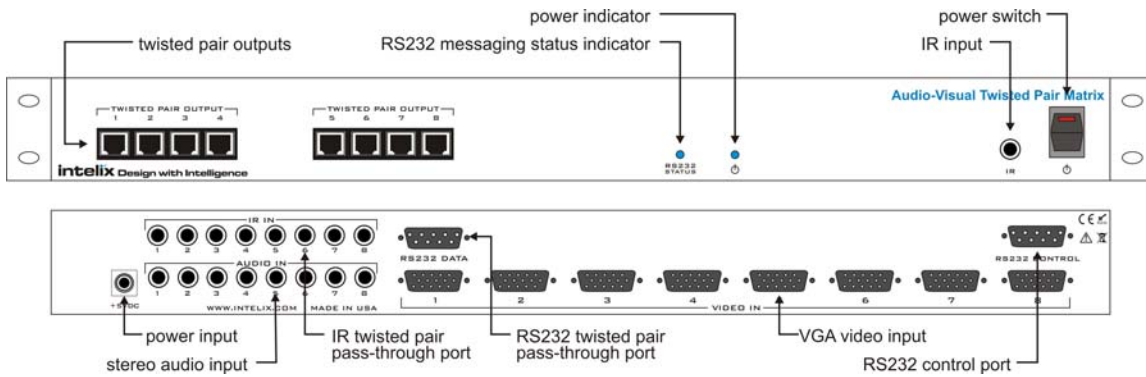

Installation

To install the Intelix DIGI-VGASD-8X8e matrix switcher, please perform the following steps.

1. If mounting in a 19" audio/video rack, verify the rack has one rack space unit (1RU) of open space.

Ventilation when Rack Mounting

- At least 2 inches of free air space is required on both sides of the DIGI-VGASD-8X8e for proper side ventilation.
- Ensure there are no closeable doors on the rack that might seal the DIGI-VGASD-8X8e from a steady supply of cool air.
- Avoid mounting the DIGI-VGASD-8X8e near a power amplifier or any other source of significant heat.
- It is recommended that you leave an empty rack space above and below the DIGI-VGASD-8X8e for additional cooling.

2. Power-off the source and destination audio and video devices.

Note: All connecting audio-visual equipment must be powered off.

3. Connect the input sources to the DIGI-VGASD-8X8e using high-quality audio and video cables.

Note: Intelix recommends labeling all analog audio and video inputs to aid in software and control system programming.

4. Connect the output destinations to the DIGI-VGASD-8X8e using twisted pair cables (compatible Intelix twisted pair receivers sold separately). Each output channel requires one run of twisted pair cable with TIA 568B terminations.

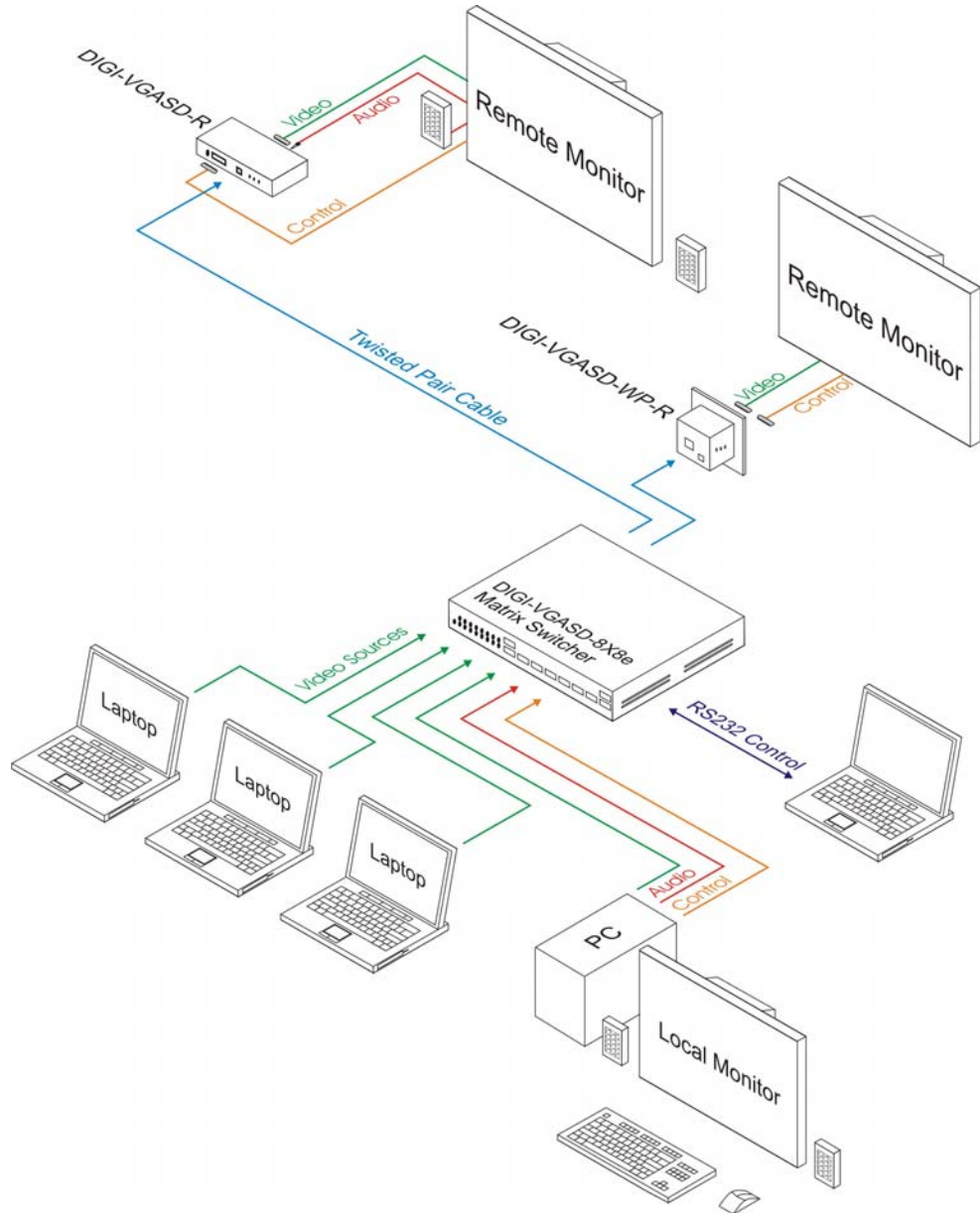

Recommended Receivers

Product	Style	Max Distance	Signals
DIGI-VGASD-R	Modular	350 feet	VGA, audio, IR RS232
DIGI-VGASD-WP-R	Wallplate	350 feet	VGA, audio, IR RS232
DIGI-V3A2-R	Modular	350 feet	YPbPr, audio
DIGI-V3SD-R	Modular	350 feet	YPbPr, audio, IR, RS232

*Note that the DIGI-VGASD-8X8e is not a scaler. Like inputs must be routed to like outputs; i.e., VGA inputs must be routed to VGA receivers, component video inputs must be routed to component video receivers, etc.

5. Connect the included power cord to the DIGI-VGASD-8X8e.
6. Connect an RS232 cable to the DIGI-VGASD-8X8e. Verify the opposite end of the cable is connected to a controller (i.e., PC running Intelix Smart Control software, touch panel, etc.).

Note: If controlling the DIGI-VGASD-8X8e matrix with Intelix Smart Control software, verify the software is properly loaded on a connected PC.

7. Power-on the DIGI-VGASD-8X8e. Verify that both front panel LEDs are illuminated. It is normal for the status light to blink.
8. Power-on the source and destination audio and video devices.

Controlling the Matrix

The DIGI-VGASD-8X8e features a bi-directional serial port for transmitting and receiving RS232 messages from a remote controller, such as a computer or touch panel.

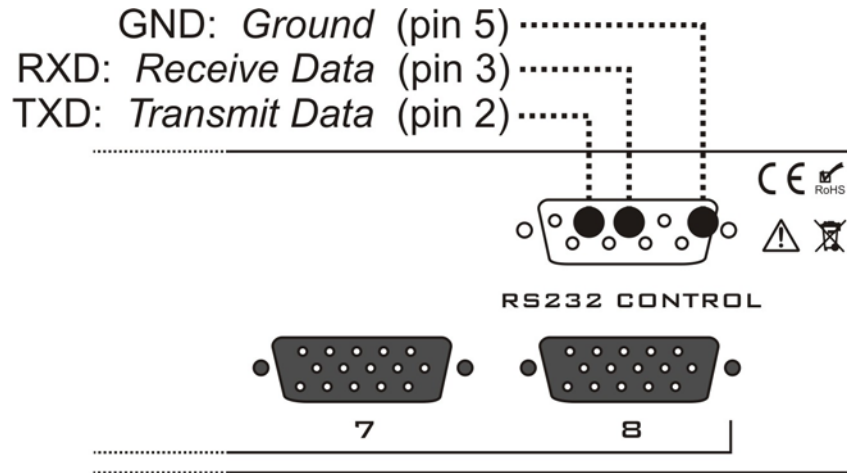

Controlling the Matrix with Intelix Smart Control Software

Intelix Smart Control software is included with each DIGI-VGASD-8X8e matrix purchase.

In order to install Intelix Smart Control software, please follow the steps below.

- 1) Insert the Intelix Software CD into the computer's CD-ROM drive.
- 2) The CD should automatically start, and the Intelix Autorun Wizard window should initiate. If this does not occur, manually select your computer's CD-ROM drive and open the *Autorun.exe*.
- 3) Select the program(s) you wish to install and follow the Installation Wizards.

Downloading the Smart Control Software Online

Intelix Smart Control software is available for download free from www.intelix.com in the Technical Library.

After installation, execute the Intelix Smart Control software on the computer.

- 1) The first screen will prompt you to load an existing configuration. If you have a pre-configured file, select *Yes*. If you are creating a new file, select *No*.

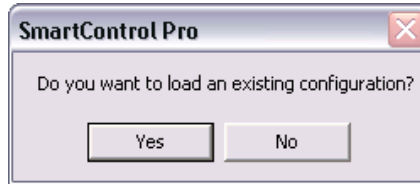

- 2) After opening your pre-configured file or creating a new file, the *Configure Router* screen will open. Select the number of DIGI-VGASD-8X8e matrices used in your application in the *Router Count* drop down menu.

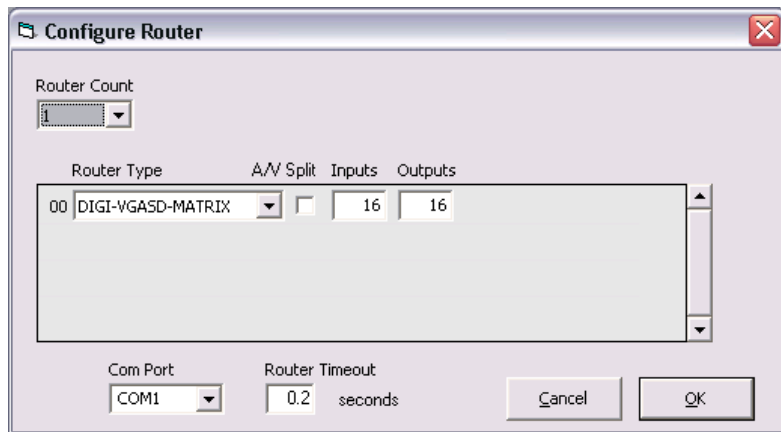

- 3) Select the number of Intelix DIGI-VGASD series matrices used in your application in the *Router Count* drop down menu.

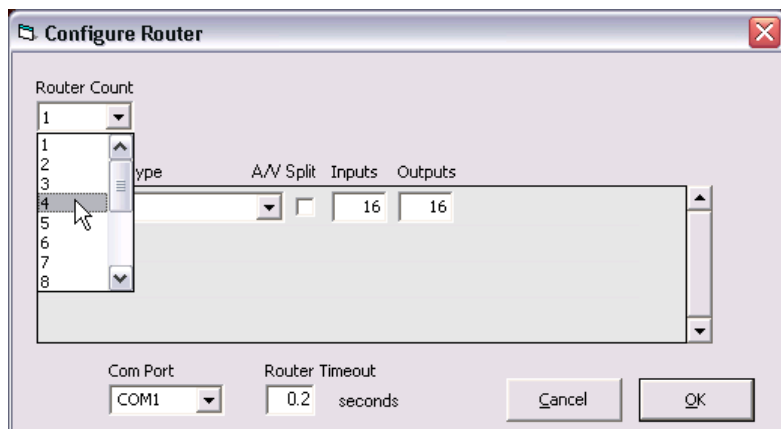

- 4) Select the Intelix DIGI-VGASD series matrix type for each router in the application.

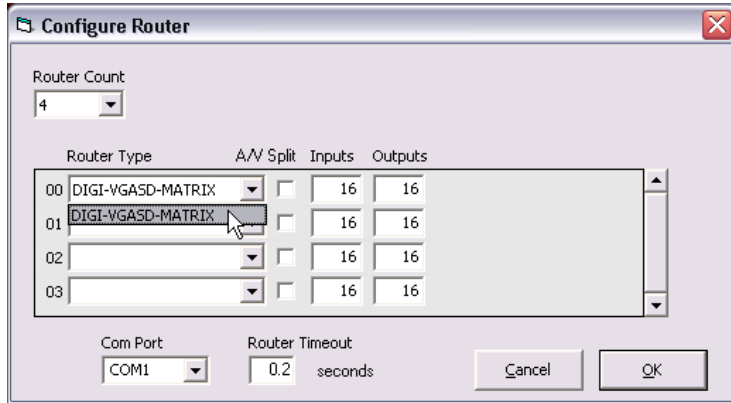

- 5) Define the quantity of inputs and outputs for each router in the application.

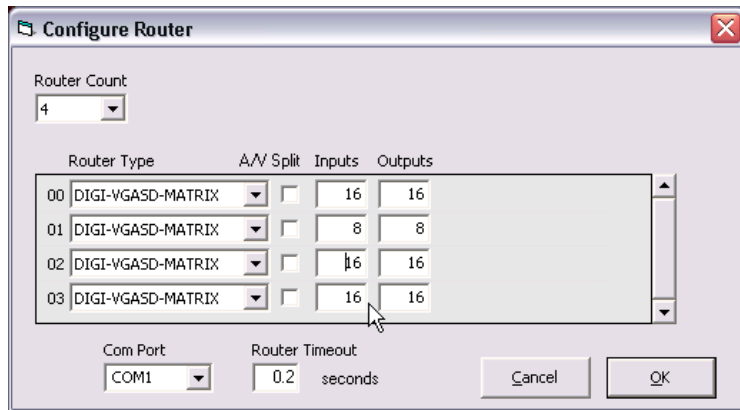

- 6) Select the Communication Port your computer or control system is using to connect to the DIGI-VGASD-8X8e matrix. Optionally, timeout speeds may be adjusted for controllers with slower connections.

Note: Router Timeout speeds should be no greater than 0.2 seconds.

- 7) After completing the *Configure Router* screen, select *OK*. The *Smart Control Pro* screen will execute.

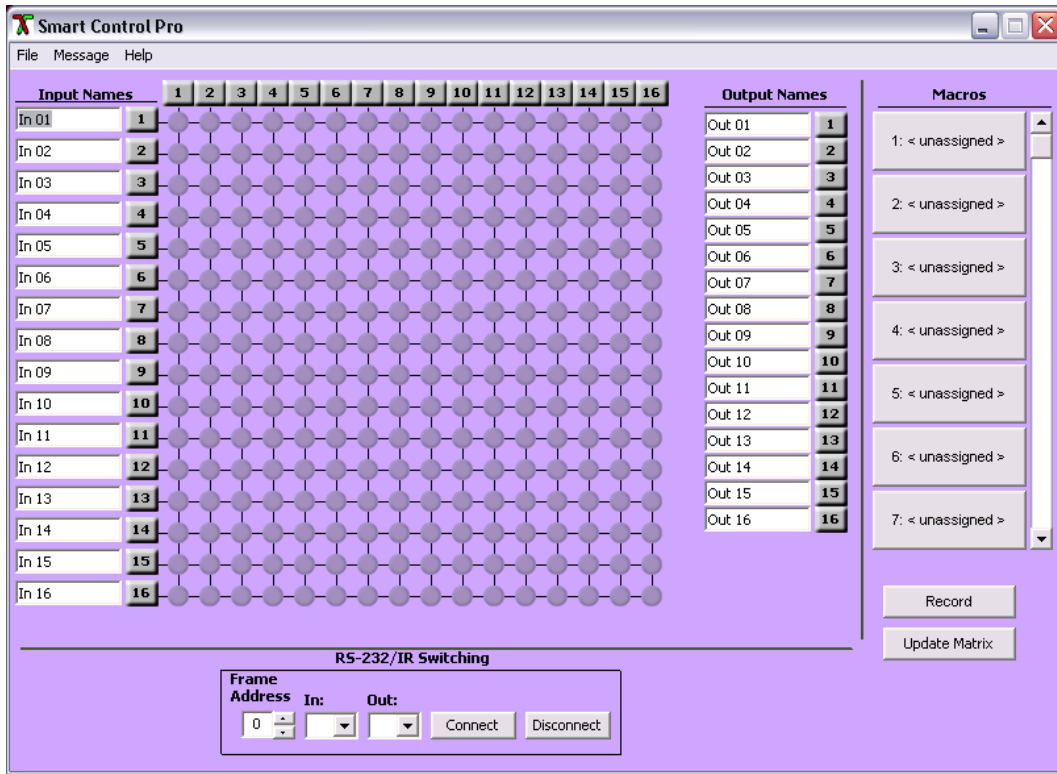

- 8) The *Smart Control Pro* screen provides easy-to-use, grid-style control of the DIGI-VGASD-8X8e matrix. Inputs are configured on the left of the screen. Outputs are configured on the top of the screen.

Note: Intelix *Smart Control* software allows each input and output to be custom labeled. Select the desired input/output and enter your label.

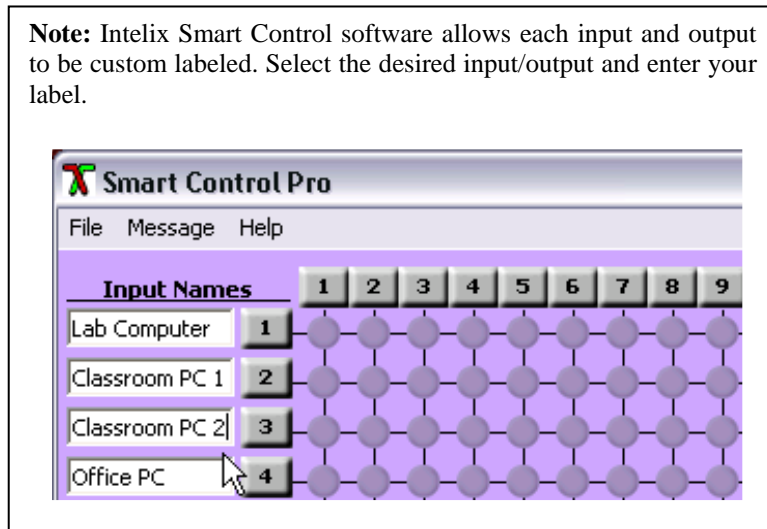

- 9) Intelix *Smart Control Pro* software provides control routing at each individual crosspoint. To route a signal, select the circle where the input and output meet.

For example, the Lab Computer may be routed to LCD 3 by selecting the third crosspoint from the left on the top row.

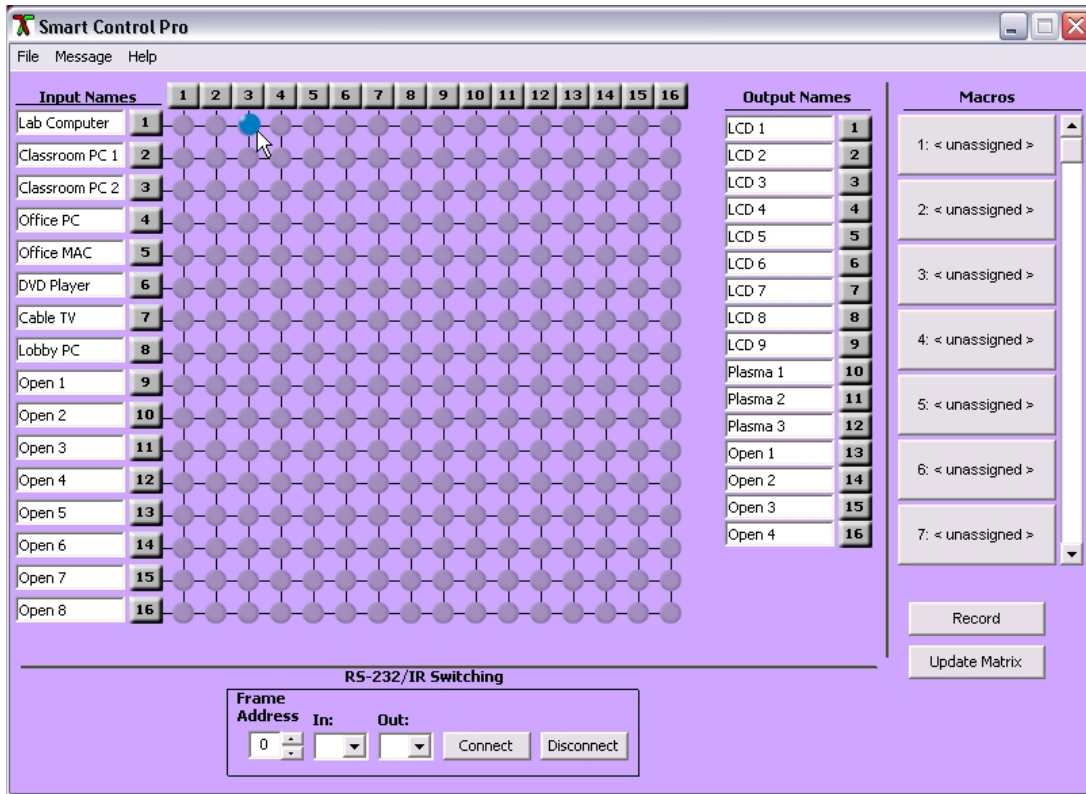

Note: Inputs may be routed simultaneously to multiple outputs, but each output may only view a single input.

Quick Click Options

Selecting multiple consecutive outputs
 Select one output crosspoint, hold the *shift* key on your keyboard, and select the last output crosspoint in the sequence

Selecting multiple outputs
 Select one output crosspoint, hold the *control* key on your keyboard, and select additional crosspoints

Routing an input to all outputs
 Hold the *control* key on your keyboard and select an input

Keeping an output selection unchanged after routing
 Hold the *shift* key on your keyboard and select an input

- 10) To record a routing sequence as a preset, or *macro*, select the *Record* button under the *Macro* header. A blinking *recording* message will appear.

Note: A macro records your clicks in the software.

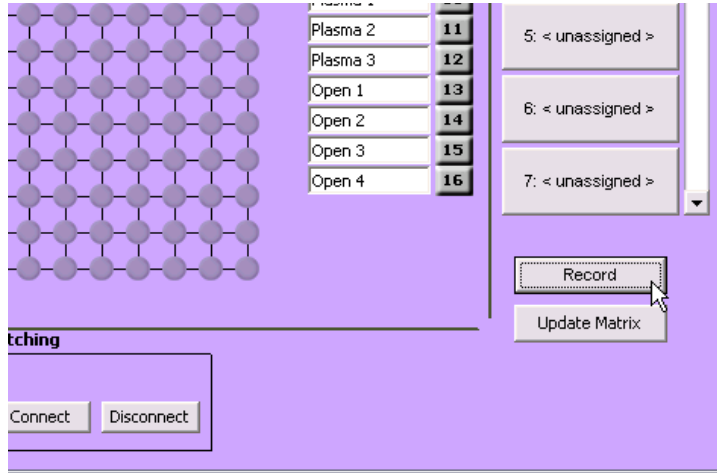

- 11) Select the desired crosspoints in the preset. There is no limit on preset routing. Select *Save Macro* when finished.

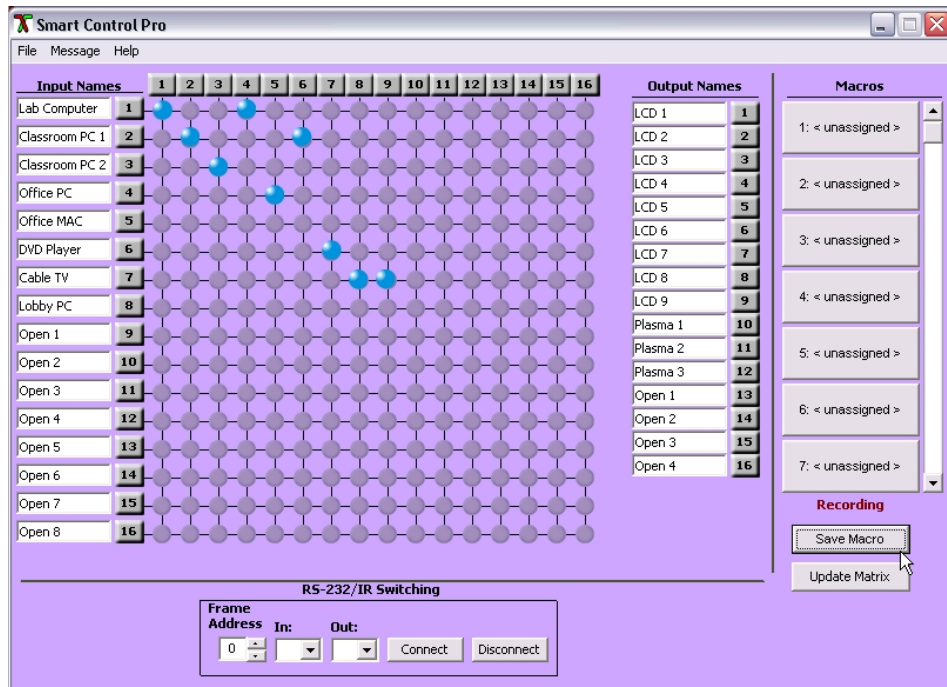

To cancel saving a macro, select the *Cancel Save* button.

- 12) Intelix Smart Control software provides up to 50 saved macros. To recall a macro, select it from the column in the *Smart Control Pro* screen.
- 13) Before exiting the Intelix Smart Control software, all desired setting and configurations should be saved in the File > Save Configuration drop down.

Controlling the Matrix with an RS232 Controller

The Intelix DIGI-VGASD-8X8e is compatible with most third-party RS232 control systems. The messaging is based on RS232 queries with CRC protocol; therefore, any system which transmits hex or ascii code is compatible with the system.

1. If controlling the DIGI-VGASD-8X8e through the RS232 control port on the rear panel, connect a straight-through serial cable directly to the matrix.
2. Power-on the DIGI-VGASD-8X8e. Verify the communication baud rate is 115,000 kbps or less.
3. Power-on the control system.

Command Protocol

Protocol

```
//FxxMyylzz<CHK><CR>
```

*All commands must start with //

ASCII Command Description

Command	Description
F	Matrix
xx	Matrix number from 00 to 99
M	Output
yy	Output number
I	Input
zz	Input number
R	Connect
D	Disconnect
nn	Matrix new frame address
<CHR>	CRC calculation
<CHK>	Exclusive OR (XOR) of all previous bytes
<CR>	Carriage return (0Dh); all commands sent from a PC end with <CR>

* CRC protocol can be disabled through the Intelix Smart Control software or by sending the following command: CRCOFF <CR>

Example Routing Command

Requirement	Code
Route input 3 to output 12	//F00M12I03<0x42><CR>

*Output command "00" routes the input to all outputs

Note: The status LED on the front panel of the matrix will blink three times when a valid command is received.

Routing RS232 from Specific Sources to Specific Destinations

The DIGI-VGASD-8X8e matrix allows RS232 commands to be transmitted from an individual input to an individual output.

Code	Description
//FxxRyyIzz<CHK><CR>	Connect to a crosspoint
//FxxDyyIzz<CHK><CR>	Disconnect to a crosspoint
//FxxFnn<CHK><CR>	Set a new frame address
//FxxU<CHK><CR>	Query a crosspoint

During a crosspoint query, the matrix will respond with one byte for each output and <CR> at the string end. The first byte transmitted refers to output 1. To calculate the input number, the matrix transmits the input number with the 7th bit set.

Transmitting Control Signals

The DIGI-VGASD-8X8e transmits bi-directional RS232 and IR over the same twisted pair output cable used for audio and video. RS232 and IR operate in different manners, and the DIGI-VGASD-8X8e handles each signal differently.

RS232 Transmission

The DIGI-VGASD-8X8e features bi-directional RS232 transmission from the matrix to remote destinations via twisted pair cable. An internal control switcher is built into the matrix, allowing serial commands to be distributed to individual channels in custom configurations. And because it is bi-directional, the matrix both sends and receives commands.

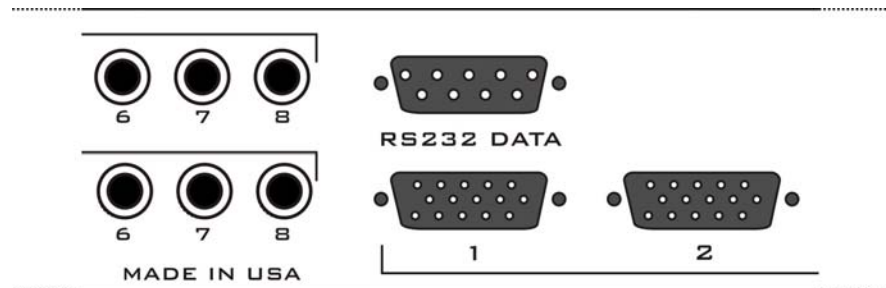

Note: The RS232 pass-through is not connected to the RS232 input of the matrix; i.e., the matrix cannot be controlled with the RS232 pass-through port.

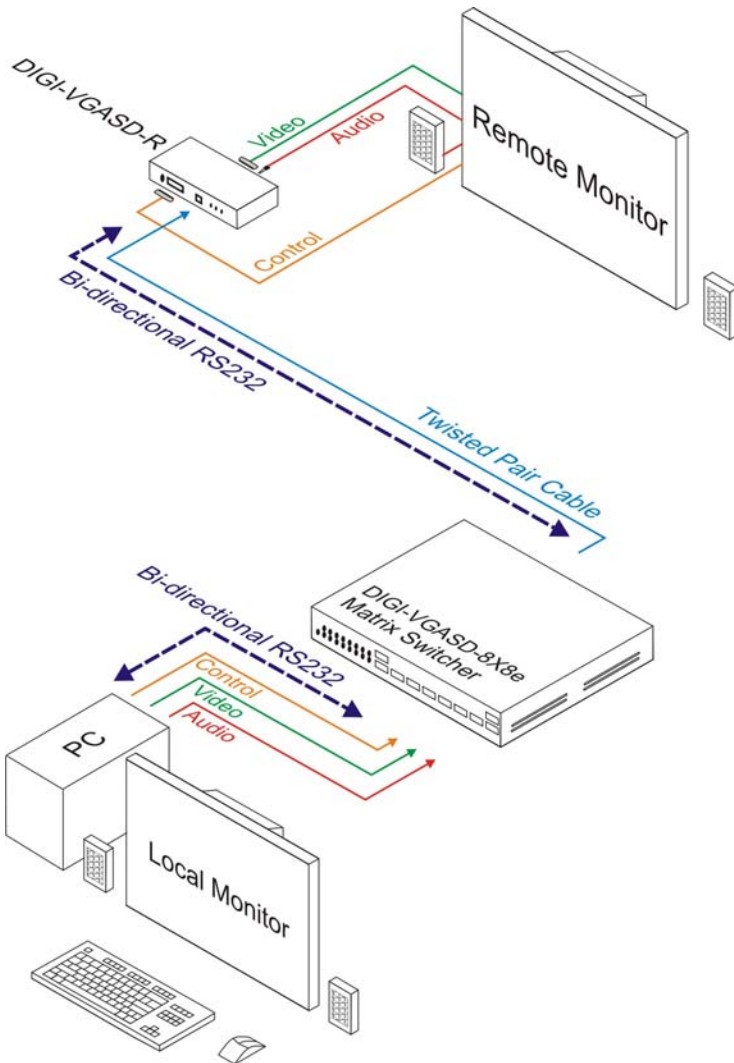

1. Connect the desired controller to the DIGI-VGASD-8X8e matrix using an RS232 (serial) cable.

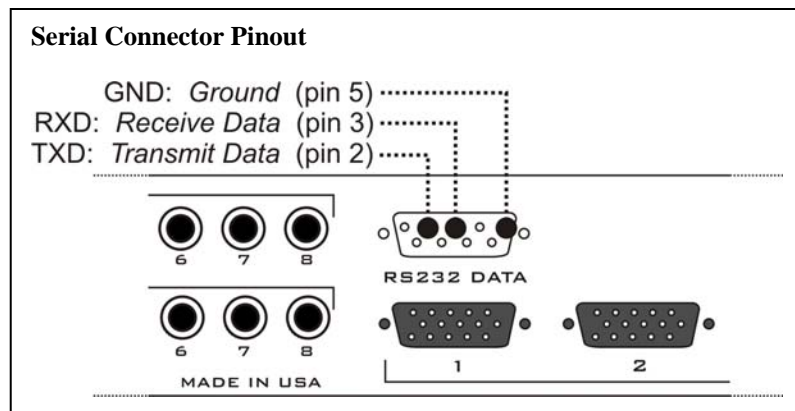

2. Verify the communication baud rate is 115,000 kbps or less.

IR Transmission

The DIGI-VGASD-8X8e features independent IR transmission for each of the matrix's eight channels. Unlike RS232, IR is not bi-directional; the Intelix DIGI-VGASD-8X8e transmits IR signals from the remote twisted pair receiver back to the matrix. The signal is then output to the active audio/video channel; i.e., if the remote monitor is viewing input channel one, the IR signal is distributed to the channel one source. This IR control configuration is ideal for remotely controlling sources, such as DVD players and satellite receivers.

Each IR channel supports infrared signals from 20 to 100 kHz.

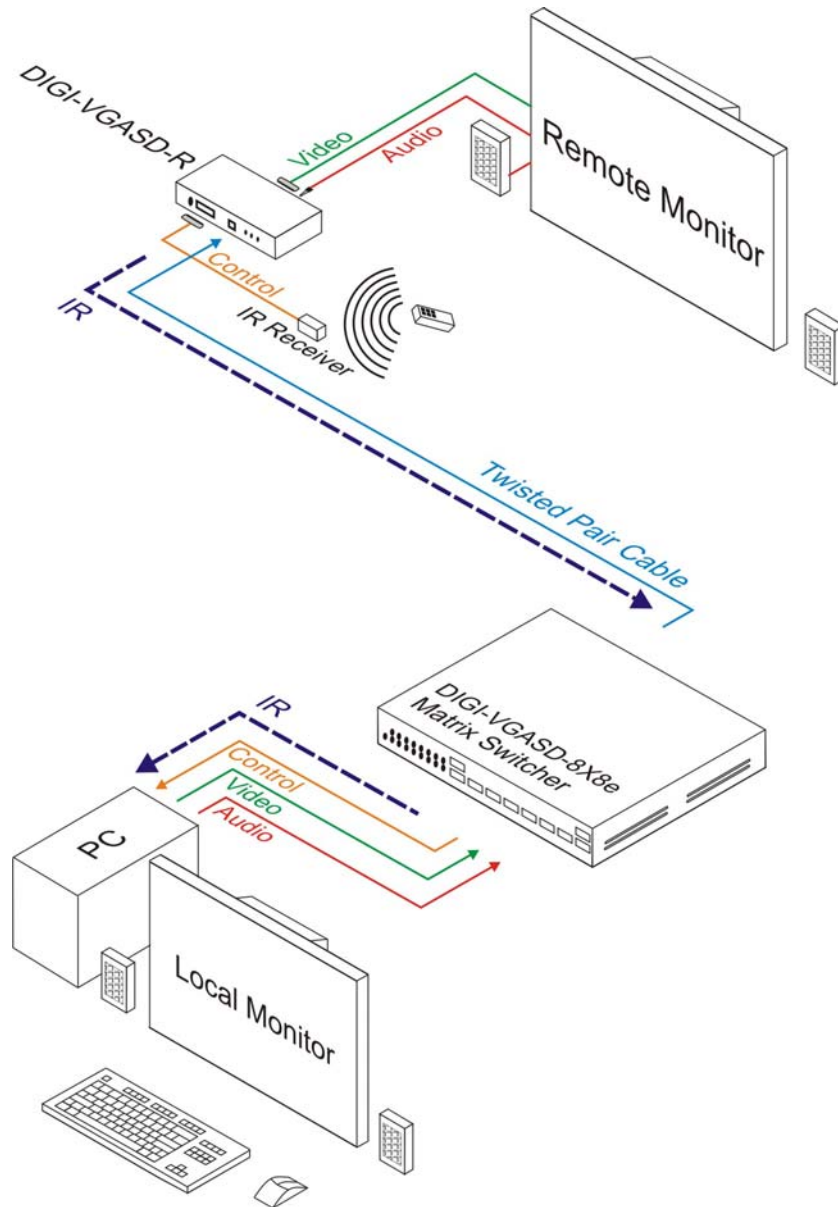

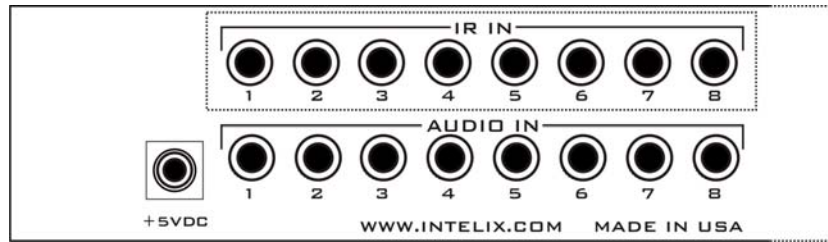

1. Verify a remote Intelix twisted pair receiver is connected to the DIGI-VGASD-8X8e matrix via twisted pair cable.
2. Connect an Intelix DIGI-VGASD-IREYE IR receiver (sold separately) to the twisted pair receiver.
3. Connect an Intelix DIGI-VGASD-IREMT IR emitter (sold separately) directly to the DIGI-VGASD-8X8e. The emitter's 1/8" mini (3.5mm) plug connects to the matrix. Each audio/video source requires an independent IR emitter.

Warning! Do *not* use any IR receiver or IR emitter other than those sold exclusively for the DIGI-VGASD series of products to prevent damage to the unit. Using 12V-based IR components may permanently damage the IR circuitry of the product and void the warranty.

4. Affix the IR emitter to the audio/video source.

IR Emitter Mounting Tips

- Surrounding electrical equipment may be producing high levels of IR noise. Plasma TVs and compact fluorescent lights are known polluters. Shield the outside of the emitter and the hardware's IR window with electrical tape.
- Verify the emitter is directly on the hardware's IR window and directly over the IR sensor. Operation may be intermittent if the emitter is too far away from the sensor.
- Clean the equipment's IR sensor window with an alcohol-based cleaner before applying the emitter to guarantee adhesion.
- Should the emitter not adhere to the equipment's sensor window, apply a small drop of glue to the adhesion pad on the emitter and re-apply.

Using the Matrix with Video Signals other than VGA

Even though the Intelix DIGI-VGASD-8X8e features HD15 (traditional VGA) style connectors, the matrix supports video formats other than VGA. Component video, composite video, and Y/C video may all be routed through the matrix; HD15 connections are extremely versatile in that they provide up to 15 active conductors. However, like inputs must be routed to like outputs.

For example, a hybrid system with component video sources (satellite receivers, DVD players, and cable receivers) and VGA video sources (laptops and computers) is supported in a single DIGI-VGASD-8X8e matrix. The component video inputs must be routed to the component video outputs. The component video inputs cannot be routed to the VGA outputs and vice versa.

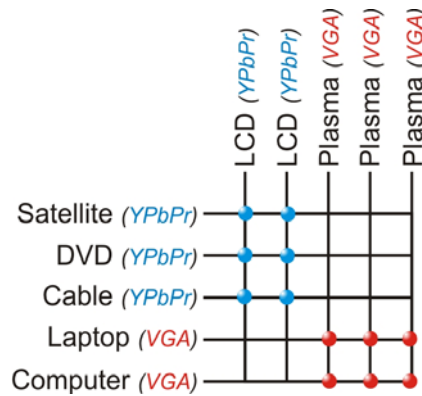

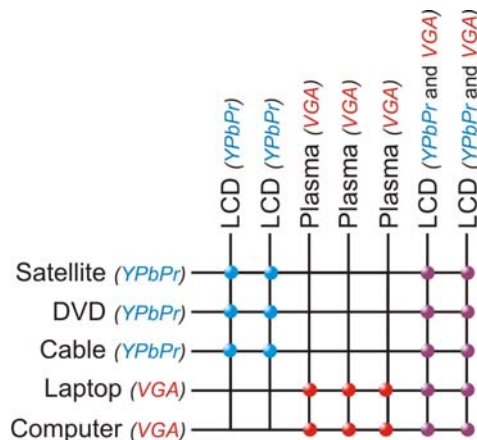

Therefore, when designing and programming a system, it is required that the input and output formats are considered and routed accordingly.

When using displays which feature multiple video input formats, it is possible to pass up to two (2) types of video signals to a DIGI-VGASD-R or DIGI-VGASD-WP-R, but only one (1) signal will be available for viewing at a time. Connect a standard VGA cable from one VGA output to the VGA input of the display and a breakout cable, such as BRKOUT-CBL, to the component video input of the display. Either video signal can now be routed to that output and viewed once the proper input source is selected on the display.



Intelix manufactures adaptor cables to convert an HD15 connector to component video, composite video, and Y/C video standards. Each converted input requires a conversion cable.

Conversion Cables

 A black cable with a female HD15 connector on one end and five male BNC connectors on the other.	BRKOUT-KIT <i>Converts (1) female HD15 connector to (5) male BNC connectors</i> <i>Ideal for RGBHV video</i>
 A black cable with a female HD15 connector on one end and three male RCA connectors (red, white, and yellow) on the other.	BRKOUT-CBL <i>Converts (1) female HD15 connector to (3) male RCA connectors</i> <i>Ideal for component video (YPbPr, RGB), Y/C video, and composite video</i>

Technical Specifications

Video Bandwidth.....	400 MHz
Maximum Resolution	1920x1080
HD Compatibility	480i, 480p, 720p, 1080i
Video Input Signal Level.....	1 volt p-p
Video Output Impedance.....	100 ohms
Video Input Impedance	75 ohms
Supported Video Formats	VGA
	SVGA
	XGA
	RGBHV
	RGsB
	CVBS
	YC
	YUV
	RGBS
	YPbPr
Sync	TTL5VDC
Sync Bandwidth.....	Horizontal sync up to 85 kHz
Control.....	RS232
Pass-through Matrix Control	RS232 and IR
Input Connectors	(8) female HD15 (video)
	(8) 1/8" mini (stereo audio)
	(8) 1/8" mini (IR)
	(1) female DB9 (serial)
Output Connectors.....	(8) RJ45
Twisted Pair Extender Max Distance	350 feet
Audio Frequency Response	20 Hz to 20 kHz
Audio Impedance.....	100 ohms unbalanced
Diagnostic.....	Front panel messaging status LED
	Front panel power LED
Operating Temperature Range.....	-41 to 95 degrees F
	-5 to 35 degrees C
Operating Humidity Range.....	5 to 90% non-condensing
Dimensions	19.00" x 1.25" x 9.25"
	1 RU
Enclosure	Black metal
Regulatory	CE, RoHS
Compatible Intelix Twisted Pair Receivers	DIGI-VGASD-R
	DIGI-VGASD-WP-R
	DIGI-V3A2-R
	DIGI-V3SD-R
Shipping Weight.....	12 lbs
Intelix Part Number	DIGI-VGASD-8X8e
Warranty	2 years



Warranty

Intelix warrants to the original purchaser of new and B-stock products that the product will be free from defects in material and workmanship for a period of 2 years from the date of purchase from an authorized Intelix reseller, subject to the terms and conditions set forth below.

All Intelix products are guaranteed against malfunction due to defects in materials or workmanship for two years after date of purchase. If a malfunction does occur during the specified period, the defective product will be repaired or replaced at Intelix's option without charge. As a condition to receiving the benefits of this warranty, you must provide Intelix with documentation that establishes you were the original purchaser of the Intelix products. If you are not the original purchaser, the Intelix equipment must be returned to the original purchaser or another authorized Intelix reseller accompanied by dated documentation of proof of purchase. Please contact Intelix for a list of authorized resellers.

This warranty does not cover: 1) Malfunction resulting from use of the product other than as specified in the user manual; 2) Installation specific wiring; 3) Malfunction resulting from abuse or misuse of the product; 4) Exterior chassis appearance; 5) Malfunction occurring after repairs have been made by anyone other than Intelix or any of its authorized service representatives; 6) Acts of nature; 7) Optional software upgrades or updates.

This warranty will be void if the product's serial number or quality control sticker has been removed or defaced, or if the product has been altered, subjected to damage or abuse, repaired by any person not authorized by Intelix to make repairs, or installed in any manner that does not comply with Intelix's recommendations.

This warranty is in lieu of all other warranties, express or implied. Intelix disclaims all other warranties, express or implied, including, but not limited to, implied warranties of merchantability and fitness for a particular purpose.

No agent or reseller of Intelix is authorized to modify this warranty or to make additional warranties on behalf of Intelix. Statements, representations or warranties made by any party other than Intelix does not constitute warranties by Intelix. Intelix shall not be responsible or liable for any statement, representation or warranty made by any other person or party.

Warranty service is only offered after a return authorization (RA) number has been generated by an authorized Intelix factory representative. If you purchased the Intelix goods directly from Intelix, please contact Intelix Applications for an RA number. If you purchased the Intelix good from an authorized Intelix reseller, please contact your authorized reseller for an RA number. This RA number must be clearly referenced on the outside of all packages shipped to Intelix. Intelix Applications must be contacted prior to any return of goods; all return shipments received by Intelix without an RA number will be refused. All shipments must be received within 30 days from the RA number issue date.

At Intelix's option, Intelix will advance replace failing Intelix goods on approved accounts within 90 days of shipment from Intelix. The advanced replaced goods will be invoiced and payment will be due under standard terms if

the failing goods are not received within 14 days of the advanced replacement shipment.

Intelix will match shipping method for units still under warranty. If a unit which is out of warranty needs repair, the dealer must pay for shipping, replacement parts, and a fixed \$100/hr* labor fee. Normal Intelix credit terms apply to billable repairs. If a unit is returned and found to work according to factory specifications, a \$100 service fee* is billed regardless of warranty status. All repairs are made in a reasonably quoted amount of time; a rush shipment fee of \$50* may apply to repairs needing a quicker than usual turn-around time.

All goods outside of the standard warranty period which are repaired by Intelix are covered by an additional 90 day warranty. This 90 day warranty only covers the specific repaired components. All other standard warranty limitations apply.

**Or current applicable rate/fee.*

Warranty terms and conditions subject to change and do not apply outside of United States and Canada.

Intelix Warranty is subject to change. Please contact the factory for the most up-to-date information.

Thank you for your purchase.

We appreciate your business. Please contact us with your questions and comments.

Intelix
2222 Pleasant View Road Suite 1
Middleton, WI 53562

Phone: 608-831-0880
Toll-Free: 866-4-MATMIX
Fax: 608-831-1833

www.intelix.com
intelix@intelix.com



Copyright 2009 Intelix LLC.
DESIGN WITH INTELLIGENCE

